

Parts and Accessories. Installation Instructions.



Rear-view camera retrofit

MINI ONE (R50)

MINI COOPER (R50)

MINI COOPER S (R53)

These installation instructions are only valid for cars with SA 609 (navigation system).

Retrofit kit No. 66 21 0 392 370
 66 21 0 303 085

Installation time

The installation time is 4,0 - 4,5 hours, but this may vary depending on the condition of the car and the equipment in it.

Important information

These installation instructions are primarily designed for use within the MINI dealership organisation and by authorised BMW service companies.

In any event the target group for these installation instructions is specialist personnel trained on MINI cars with the appropriate specialist knowledge.

All work must be completed using the latest BMW repair manuals, circuit diagrams, servicing manuals and work instructions in a rational order using the prescribed tools (special tools) and observing current health and safety regulations.

To avoid unnecessary extra work and/or costs, if any installation or function problems occur, after a brief troubleshooting session (approx. 0.5 hours), an inquiry is to be sent straight away to the technical parts support via the Aftersales Assistance Portal (ASAP), quoting the chassis number, the part number of the retrofit kit and a precise description of the problem.

Do not archive the hard copy of these installation instructions since daily updates are made by ASAP.

See ASAP for details of the pictograms.

Ensure that the cables/lines are not kinked or damaged as you install them in the car. The costs incurred as a result of this will not be reimbursed by BMW AG.

Additional cables/lines that you install must be secured with cable ties.

If the specified PIN chambers are occupied, bridges, double crimps or twin-lead terminals must be used.

All the figures show LHD cars, proceed in exactly the same way on RHD cars.

Pictograms



Denotes instructions that draw your attention to dangers.



Denotes instructions that draw your attention to special features.

◀ denotes the end of the instruction or other text.

Subject to technical modifications.

Ordering instructions

The additional switchbox kit is not included in the retrofit kit and must be ordered separately (see EPC for part number and documentation).

The handle strip seal **N** is not included in the installation kit and must be ordered separately (see EPC for part number and details).

List of special equipment

The following special equipment must be taken into consideration when installing the retrofit kit:

SA 609 Navigation system

Special tools required

None

Contents

Section	Page
1. Rear-view camera parts list	4
2. Additional switchbox kit parts list	5
3. Preparations	6
4. Connection diagram	7
5. Installation and cabling diagram	9
6. To install the rear-view camera and button	10
7. To install and connect wiring harness A	12
8. To install the switchbox	13
9. To connect the switchbox	14
10. Concluding work and coding	16
11. Rear-view camera circuit diagram	17

1. Rear-view camera parts list

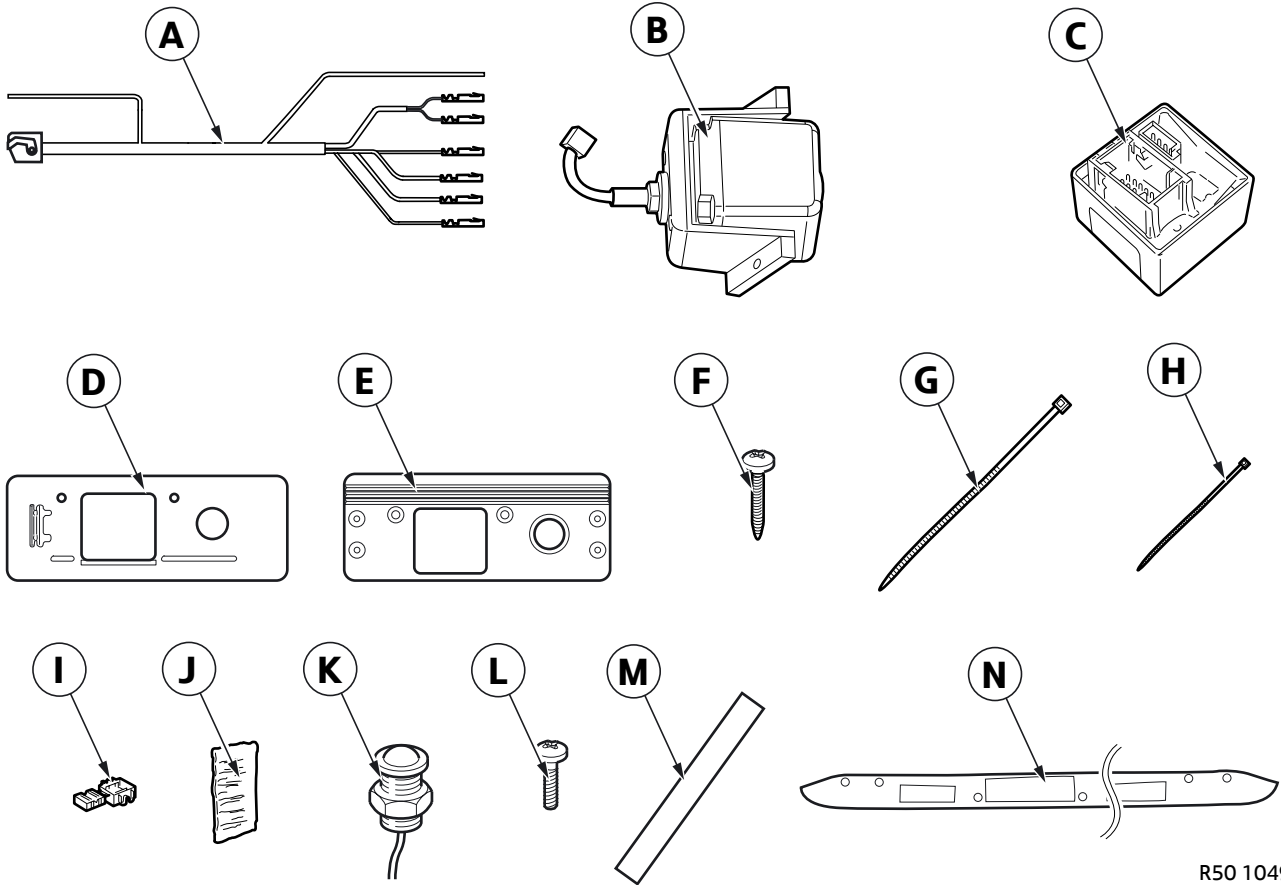

R50 1049 Z

Legend

- A Wiring harness
- B Rear-view camera
- C Control module
- D Mounting plate (not required)
- E Mounting plate
- F Philips screw 3.5 x 16 (6x)
- G Cable tie 292 x 4.8 mm (1x)
- H Cable tie 200 x 3.6 mm (20x)
- I Miniature connector (5x)
- J Protective strip
- K Button
- L Philips screw 3.5 x 9.5 mm (4x)
- M Sealing strip
- N Handle strip seal (not supplied with retrofit kit)

2. Additional switchbox kit parts list

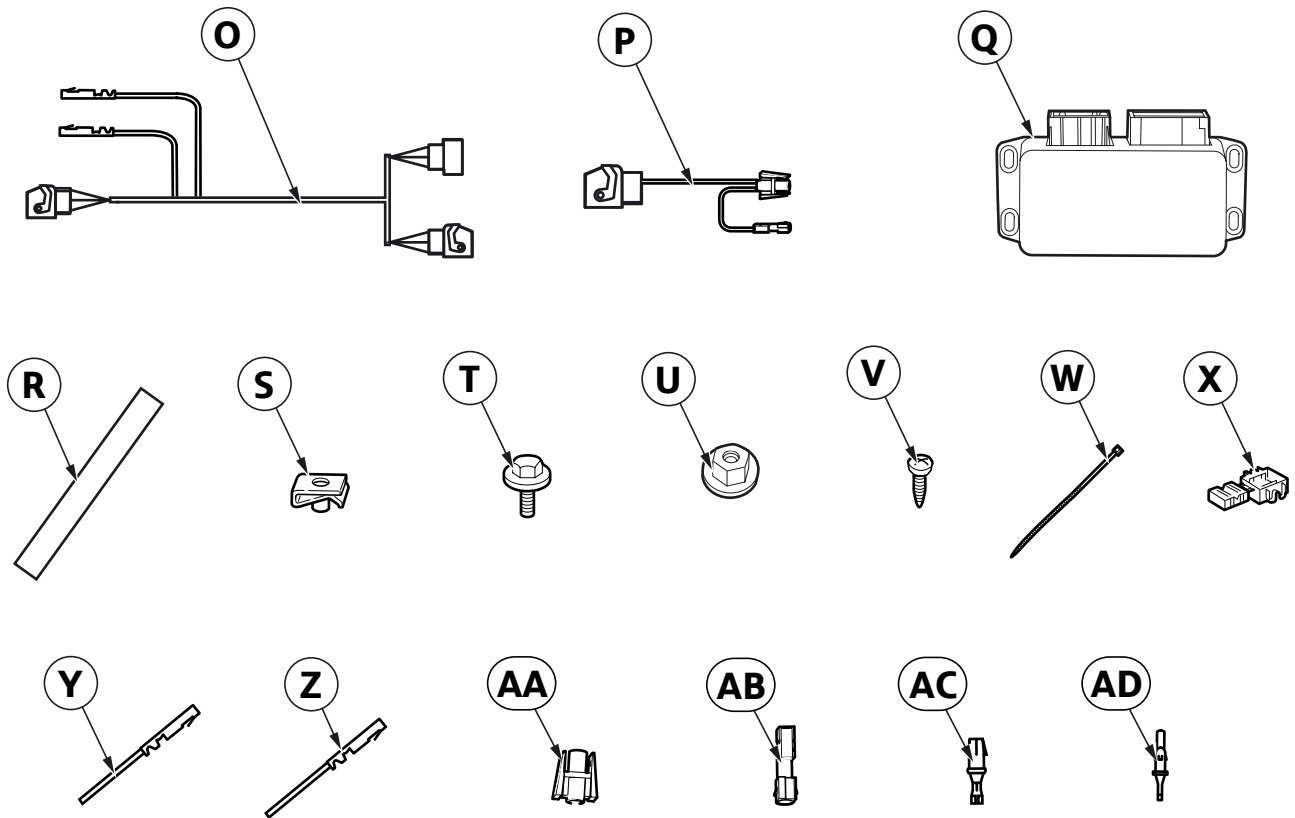

R50 1041Z

Legend

O	Adapter cable	W	Cable tie 200 x 3.6 mm (10x)
P	Supply cable	X	Miniature connector (3x)
Q	Switchbox	Y	Connection cable, RT (not required)
R	Sealing strip (2x, not required)	Z	Connection cable, BR (not required)
S	Speed nut M5 (4x)	AA	Socket casing
T	Hexagonal screw with washer M5 x 14 (4x)	AB	Plug casing
U	Hexagonal nut with washer M5 (4x, not required)	AC	Socket contact
V	Phillips head screw ST 4.2 x 13 mm (4x, not required)	AD	Plug contact

3. Preparations

	TIS No.
Conduct a brief test	---
Disconnect the negative pole of the battery	12 00 ...
The following components must be removed first of all	
Front passenger seat	52 13 000
Rear seat	52 20 010
Backrest for rear seat, right	52 20 070
Right door sill cover strip	51 47 000
Navigation computer	65 90 510
Right trim for rear window frame (boot lid)	51 49 003
Top trim for boot lid (tailgate)	51 49 006
Bottom trim for boot lid (tailgate)	51 49 005
Handle strip (boot lid)	51 13 402
Remove the handle strip seal (boot lid)	---
Roof pillar trim, rear right (C pillar)	51 43 251
Undo the interior roof trim at the rear (headlining)	51 44 001
Boot floor trim	51 47 101
Side trim at the rear right	51 43 002

4. Connection diagram

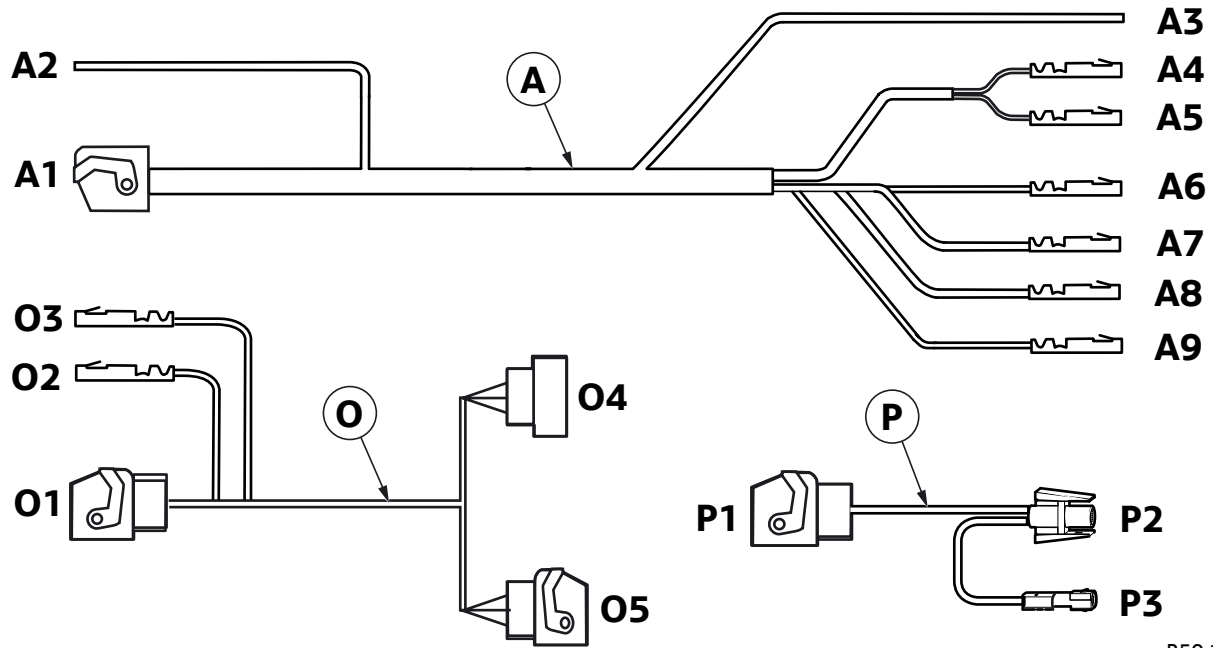

R50 1050 Z

Branch/Item	Description	Signal	Cable colour / Cross-section	Connection location in the car	Abbreviation / Slot
A	Wiring harness	---	---	---	---
A1	Black 12-pin socket casing	---	---	To control module C	---
A2	Cable open	RFS	GN 0.75 mm ²	Insulate and tie back	---
A3	Cable open	RFS	GN 0.75 mm ²	On the right-hand side of the boot, with miniature connector to BL/GE cable on the standard wiring harness	---
A4	Socket contact	Video +	transparent 0.14 mm ²	To branch P1	PIN 24
A5	Socket contact	Video -	SW/BR 0.35 mm ²	To branch P1	PIN 11
A6	Socket contact	RSF inv	SW 0.25 mm ²	To branch P1	PIN 23
A7	Socket contact	Terminal 30	RT 0.75 mm ²	To branch P1	PIN 25
A8	Socket contact	Terminal 31	BR 0.75 mm ²	To branch P1	PIN 12
A9	Socket contact	TA	WS 0.25 mm ²	Insulate and tie back	---

4. Connection diagram

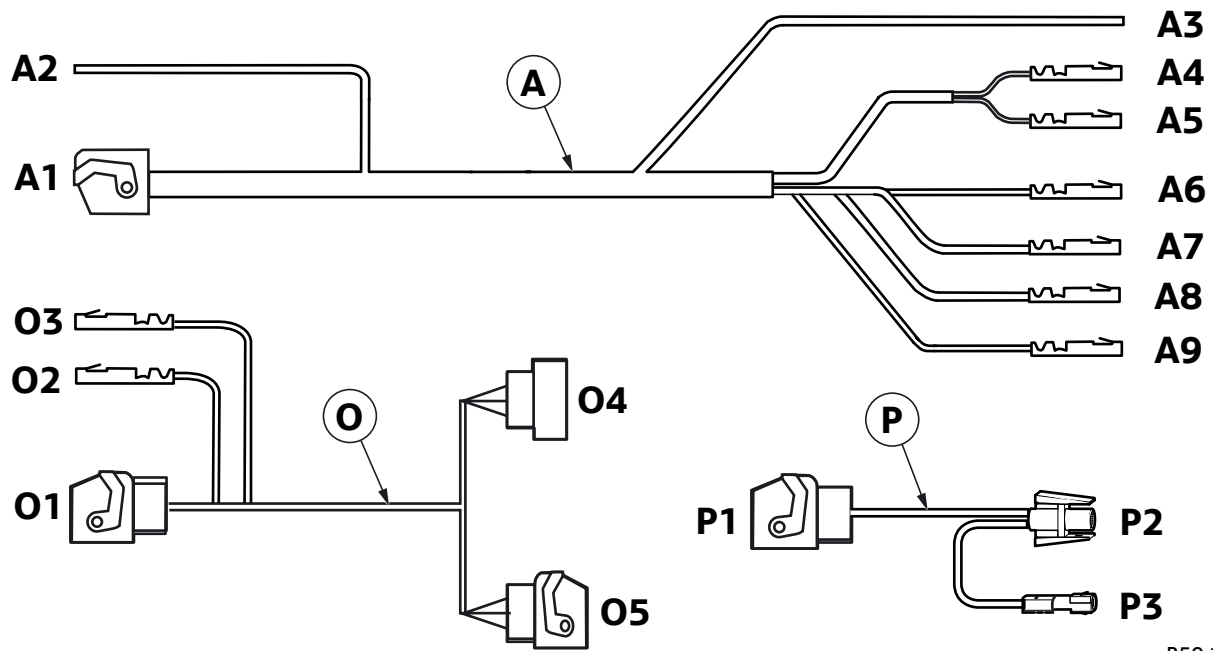

R50 1050 Z

Item	Description	Signal	Cable colour / Cross-section	Connection location in the car	Abbreviation / Slot
O	Adapter cable	---	---	---	---
O1	18-pin natural socket casing	---	---	To the switchbox Q	---
O2	Socket contact	Terminal 30	RT/GE 0.75 mm ²	To branch P1	PIN 26
O3	Socket contact	Terminal 31	BR 0.75 mm ²	To branch P1	PIN 13
O4	18-pin BL plug casing	---	---	To standard wiring harness	X1312
O5	18-pin BL socket casing	---	---	To navigation computer	X1312
P	Supply cable	---	---	---	---
P1	26-pin BL socket casing	---	---	To the switchbox Q	---
P2	Black 1-pin socket casing	Terminal R	VI/WS 0.50 mm ²	To navigation computer, twin-lead terminal with terminal parts AA - AD to the VI/BL cable	X1313 PIN 3
P3	SW 1-pin plug casing	Terminal R	VI/WS 1.50 mm	To navigation computer, twin-lead terminal with terminal parts AA - AD to the VI/BL cable	X1313 PIN 3

5. Installation and cabling diagram

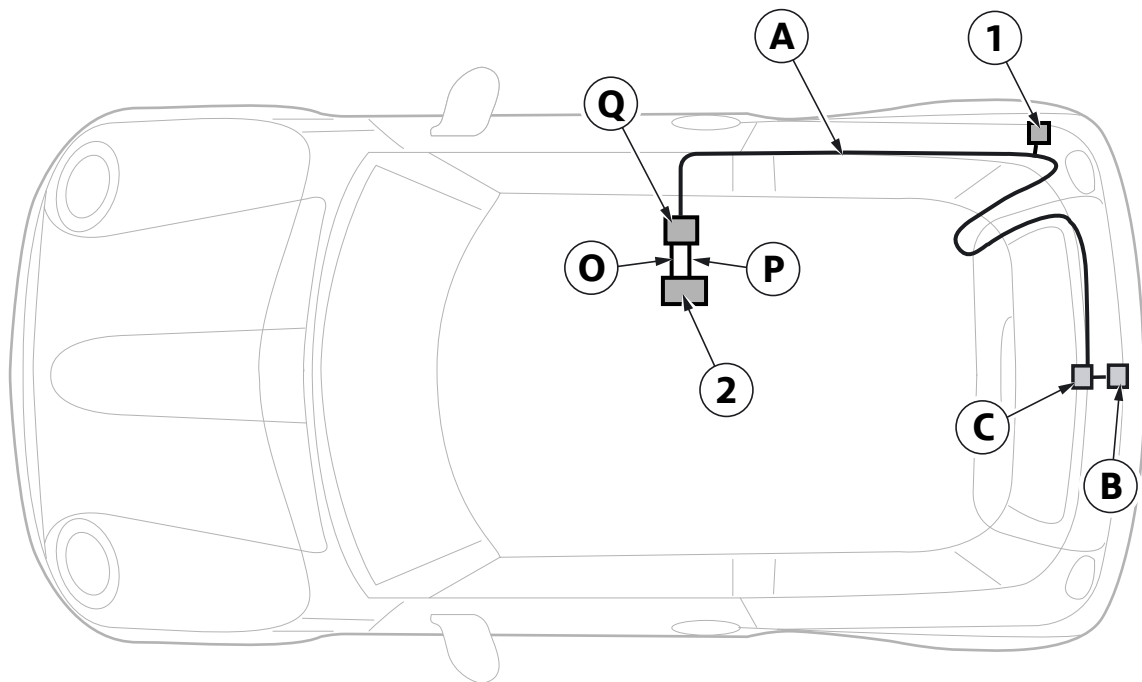

R50 1051 Z

Legend

- A Wiring harness
 - B Rear-view camera
 - C Control module
 - O Adapter cable
 - P Supply cable
 - Q Switchbox
-
- 1 Terminal RFS pick-up
 - 2 Navigation computer

6. To install the rear-view camera and button

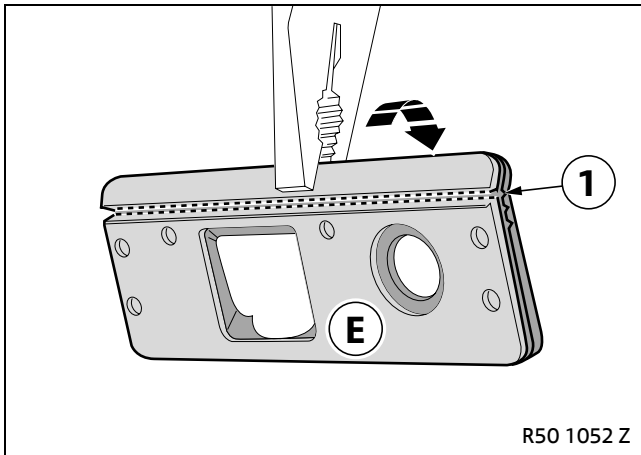

▶ The seal may have to be raised slightly to make the notches visible. ◀

Cut the seal and mounting plate **E** along the first notch (1) with a knife.

Break the mounting plate **E** and deburr it along the broken edge.

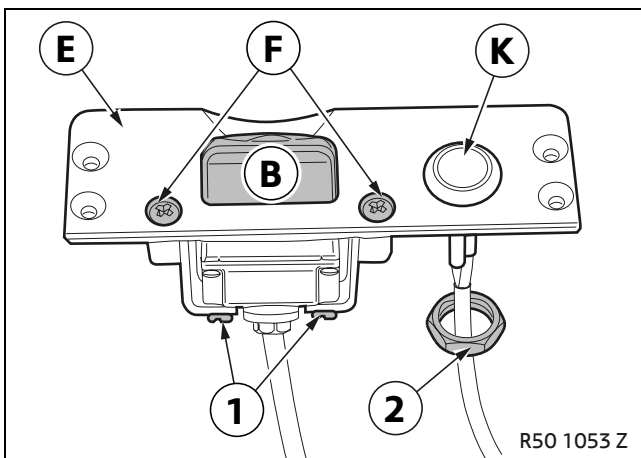

▶ There must be a seal between the mounting plate **E** and the rear-view camera **B**. ◀

Secure the rear-view camera **B** on the mounting plate **E** with screws **F**.

Align the rear-view camera **B** using the screws (1) if necessary, at right-angles to the mounting plate **E**.

Insert the button **K** into the trim **E** and secure it with a union nut (2).

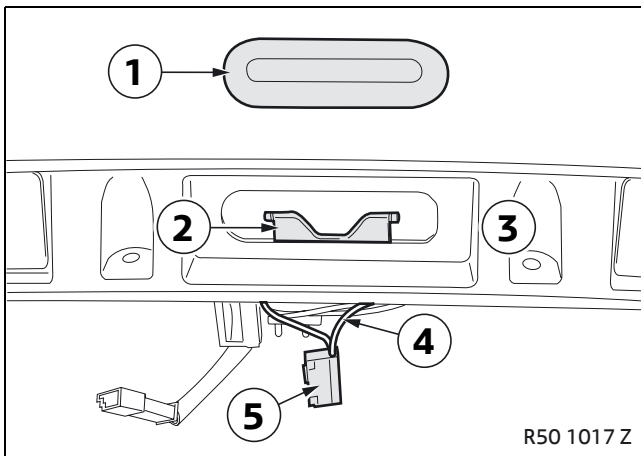

Unclip the rubber cover (1) and rocker arm (2) from the handle strip (3).

Cut both cables (4) on the button (5).

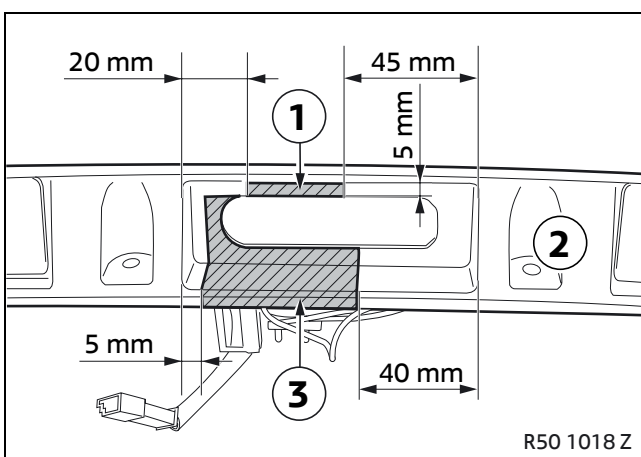

Draw the specific dimensions on the handle strip (2).

- Saw out the handle strip (2) in the marked area (3).
- File off the handle strip (2) in the marked area (1), or cut it out with a knife.

6. To install the rear-view camera and button

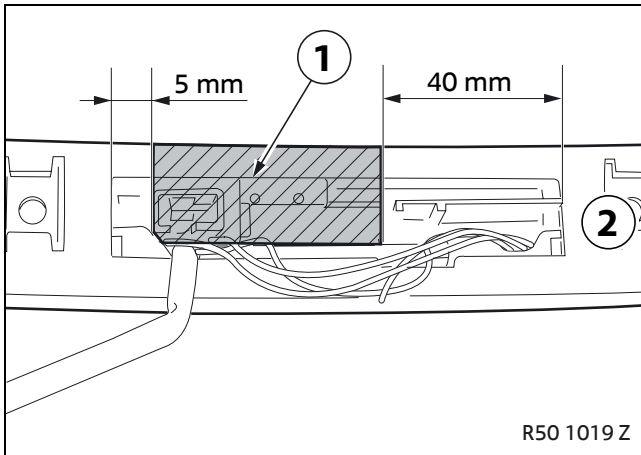

Draw the specific dimensions on the handle strip (2).

- Saw out the handle strip (2) in the marked area (1)

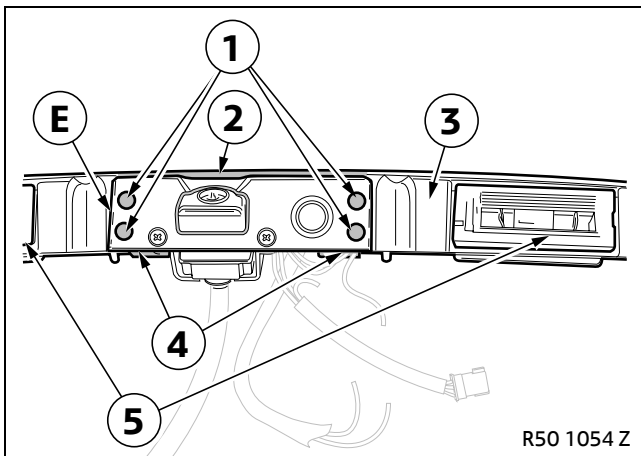

Align the mounting plate E on the handle strip (3) as follows:

- Mounting plate E in the centre between the registration plate lights (5)
- The mounting plate seal E must be on the handle strip (3) at the rear (2)
- Edge (4) flush with the handle strip (3)

Mark the holes (1) from the mounting plate E on the handle strip (3) and drill them with a 3 mm twist drill bit.

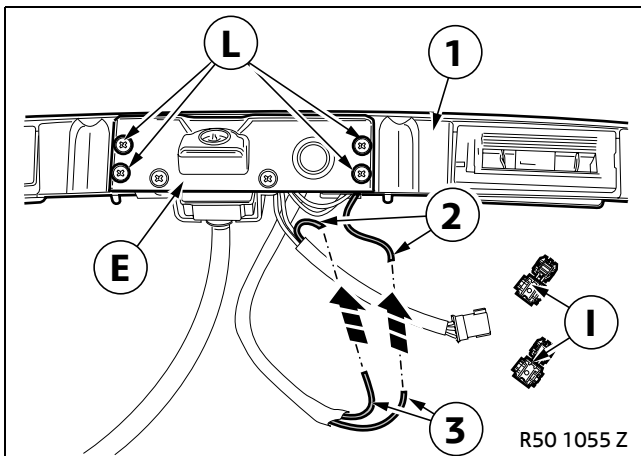

Secure the mounting plate E on the handle strip (1) with screws L.

Connect the cable (3) for the button to the open cables (2) using miniature connectors I.

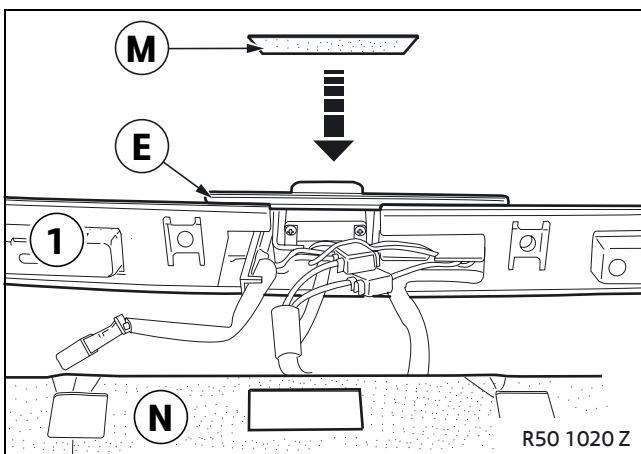

▶ There area between the mounting plate E and handle strip (1) must be sealed. If the gap between the seal N and the mounting plate E is too large, use additional sealing strips M. ◀

Affix the seal N on the handle strip (1) and affix the mounting plate E.

Fit the handle strip (1).

7. To install and connect wiring harness A

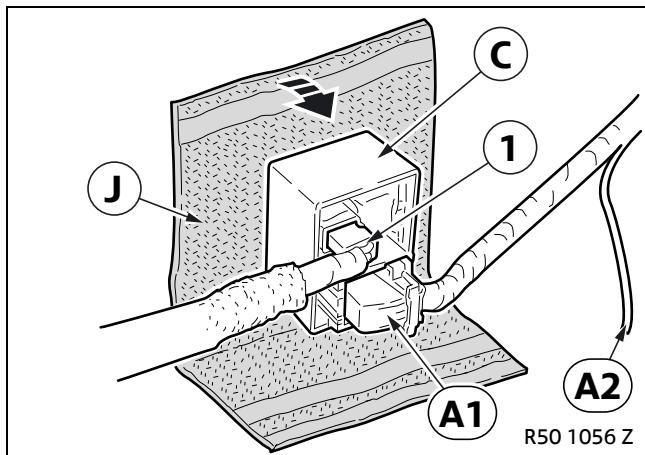

Connect the connection plug (1) of the rear-view camera and branch **A1** (socket casing, 12-pin SW) to the control module **C**.

Insulate branch **A2**, GN cable, and tie it back.

Affix the protective strip **J** to the control unit **C**.
Cut off any excess lengths.

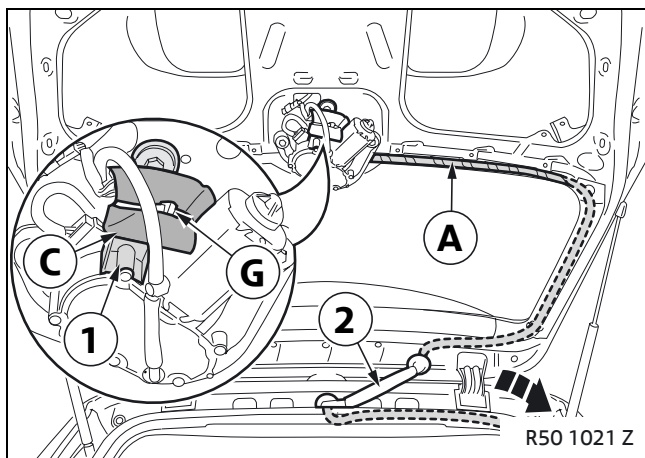

Use a cable tie **G** to secure the control module **C** to the strut (1) for the wiper motor.

Route the wiring harness **A** through the grommet (2) to the right C pillar.

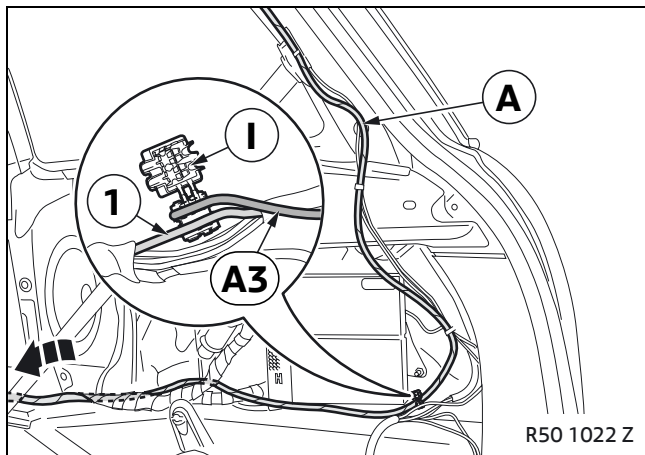

Route wiring harness **A** along the standard wiring harness to the right side of the boot.

Connect branch **A3**, GN cable, to the standard wiring harness as follows:

- Expose the BL/GE cable (1)
- Check whether terminal RFS is activated on the cable (1) when reverse gear is engaged
- Connect branch **A3** using a miniature connector.

Route the wiring harness **A** to the central entry area.

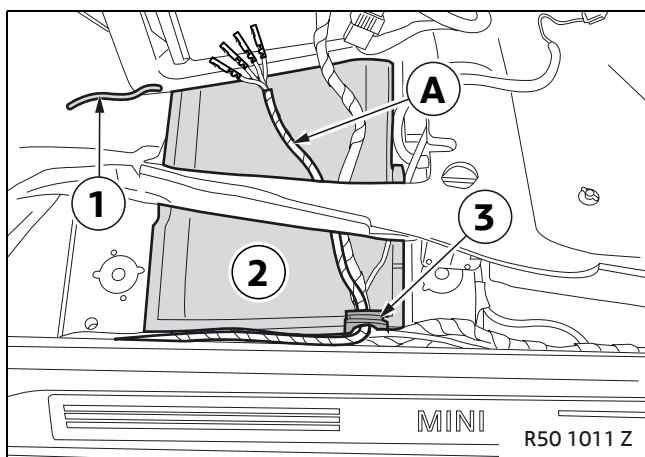

Route the wiring harness **A** through the grommet (3) into the floor pan (2).

Remove the insertion tool (1).

8. To install the switchbox

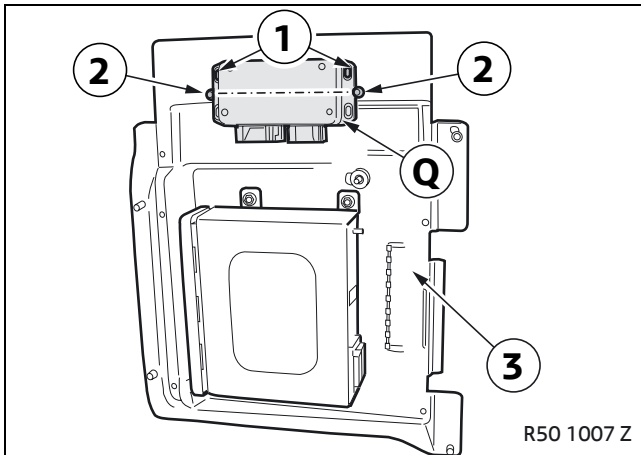

Position the switchbox **Q** in the centre between the two coarse thread stud bolts (**2**) on the cover (**3**).

Mark the holes (**1**) and drill through the cover (**3**) with an 8 mm twist drill bit.

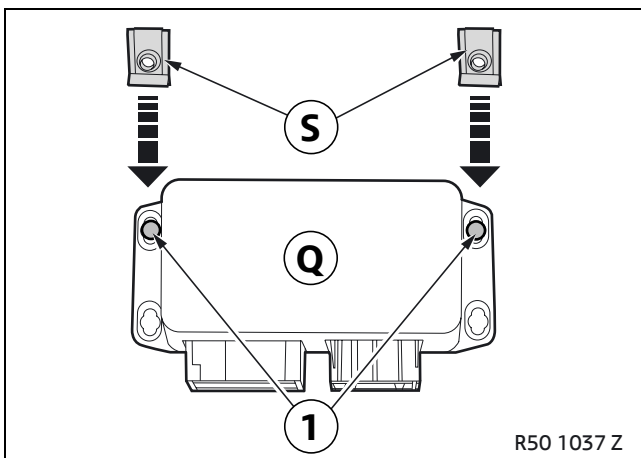

Enlarge the holes (**1**) in the switchbox **Q** with an 8 mm twist drill bit.

Fit speed nuts **S**.

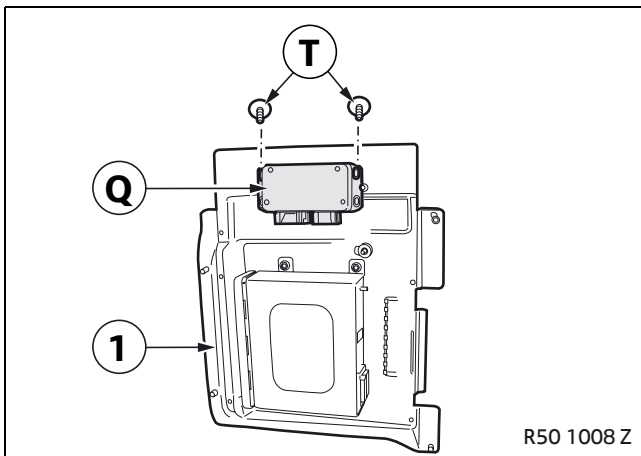

Secure the switchbox **Q** to the cover (**1**) using hexagonal screws **T**.

9. To connect the switchbox

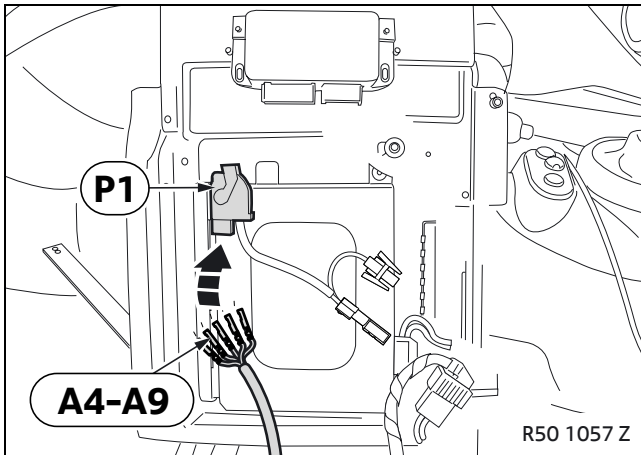

Insulate branch **A9**, white cable, and tie it back.

Connect branches **A4 – A8** to branch **P1** as follows:

- Branch **A4**, transparent cable, to PIN 24
- Branch **A5**, SW/BR cable, to PIN 11
- Branch **A6**, SW cable, to PIN 23
- Branch **A7**, RT cable, to PIN 25
- Branch **A8**, BR cable, to PIN 12

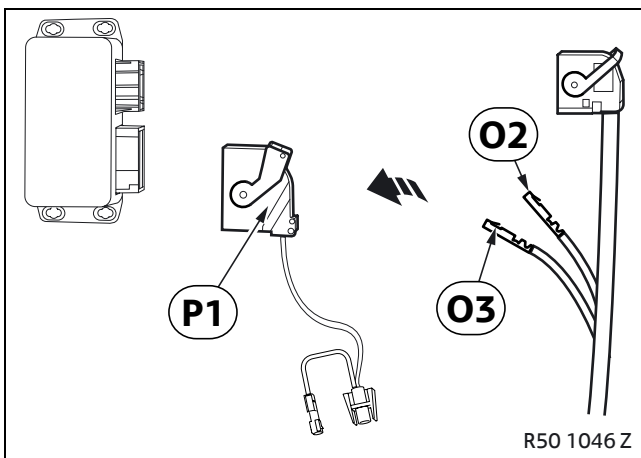

Connect branches **O2** and **O3** into branch **P1** as follows.

- Branch **O2**, RT/GE cable, to PIN 26
- Branch **O3**, BR cable to PIN 13

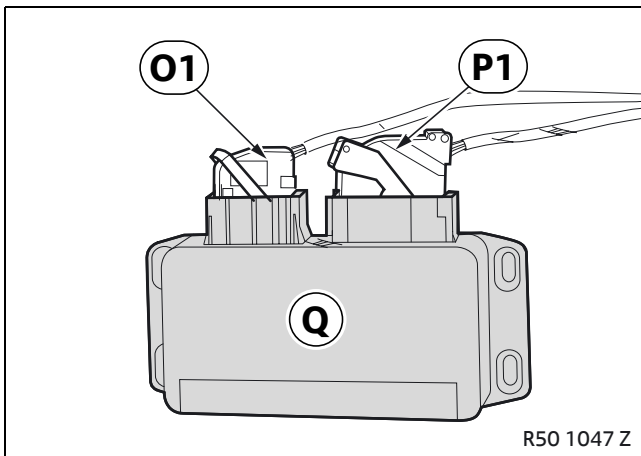

Connect branches **O1** and **P1** to switchbox **Q**.

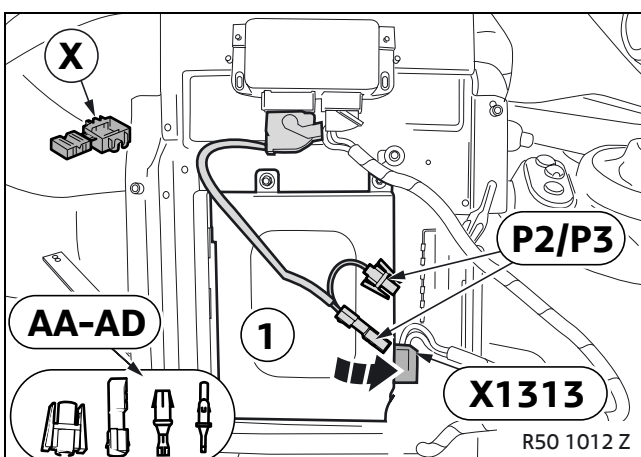

Route branches **P2** and **P3**, VI/WS cables to the navigation computer (1).

☐ If the VI/BL cable has a cross-section greater than 0.75 mm², use a twin-lead terminal with the terminal parts **AA – AD**. ◀

Cut the socket contact off branch **P2** and connect it to the VI/BL cable from plug **X1313** (18-pin socket casing Bordeaux, PIN 3) using a miniature connector **X**.

9. To connect the switchbox

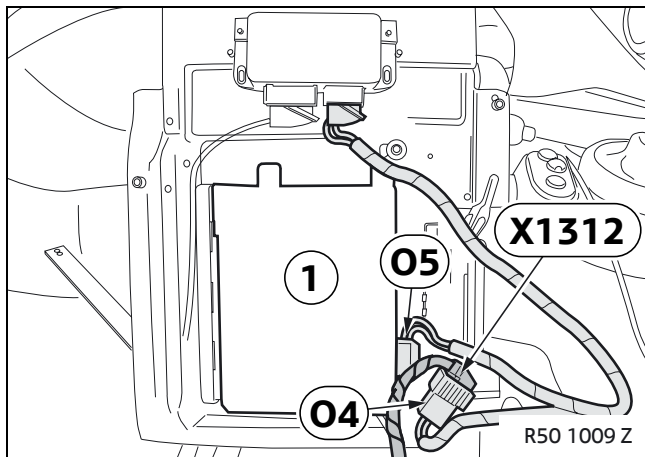

Route branches **04** and **05** to the navigation computer (1).

Disconnect plug **X1312** (18-pin BL socket casing) from the navigation computer (1).

- Connect branch **04** to plug **X1312**
- Connect branch **05** to the navigation computer (1)

10. Concluding work and coding

This retrofit system does not require coding.

- Connect the battery
- Conduct a brief test

Check the function of the rear-view camera as follows:

- Switch on the ignition
- Engage reverse; an image must appear on the on-board monitor
- Disengage reverse gear; the on-board monitor must switch over after approx. 5 seconds

- Re-assemble the car

11. Rear-view camera circuit diagram

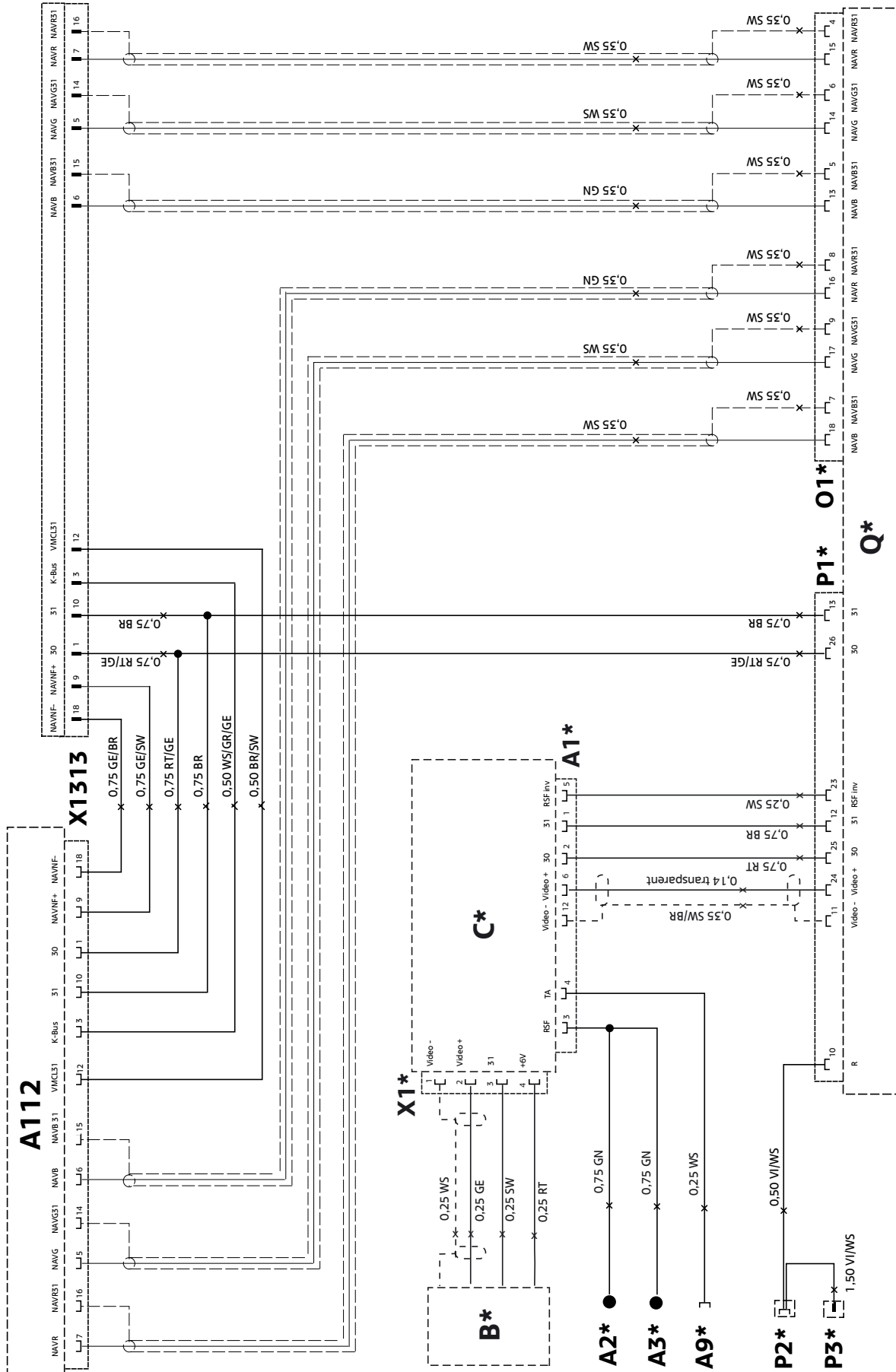

R50 1058 Z

11. Rear-view camera circuit diagram

Legend

A112	Navigation computer
B*	Rear-view camera
C*	Control module
Q*	Switchbox
A1*	Black 12-pin socket casing
A2*	Open cable, insulate and tie back
A3*	Open cable, RFS terminal pick-up
A9*	Socket contact, insulate and tie back
O1*	18-pin natural socket casing
P1*	26-pin BL socket casing
P2*	1-pin socket casing SW, terminal R tap
P3*	1-pin plug casing SW, terminal R tap
X1*	SW 4-pin plug
X1312	BL 18-pin plug

All the designations marked with an asterisk (*) apply only to these installation instructions or this circuit diagram

Cable colours

BL	Blue
BR	Brown
GE	Yellow
GN	Green
GR	Grey
RT	Red
SW	Black
VI	Violet
WS	White